

Insert Valve™

RW - Gate Sizes 4" - 12"

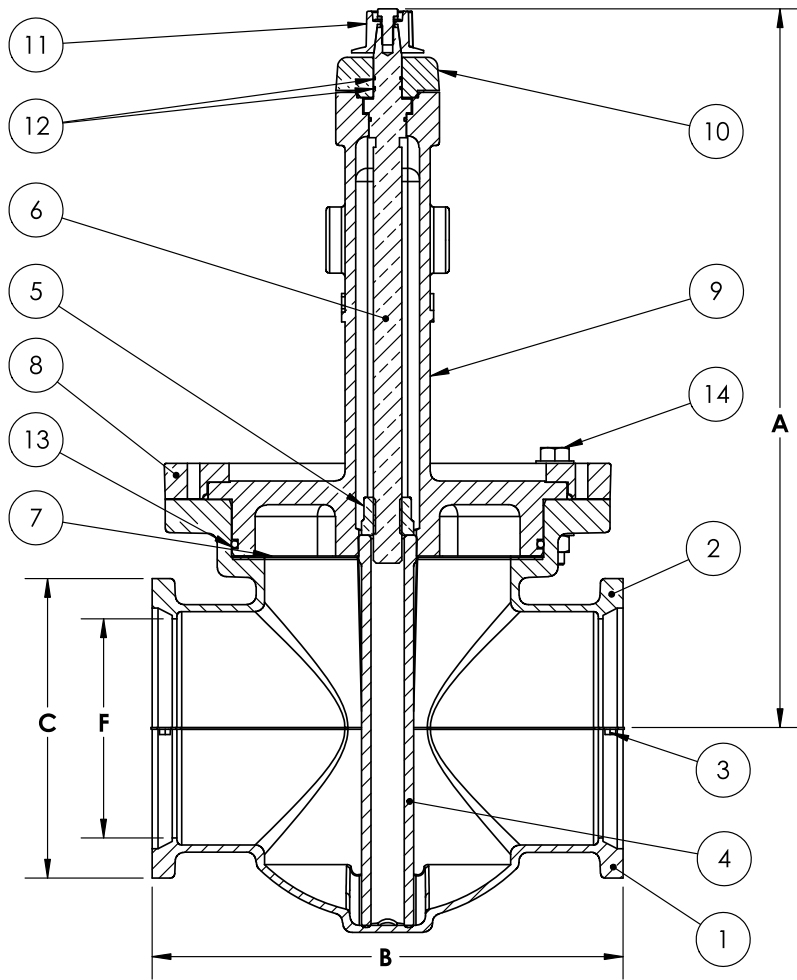

| NO. | PART | MATERIAL |
|-----|-------------------------------|---------------------------------------|
| 1 | Valve Body Bottom | Ductile Iron ASTM A536 65-45-12 |
| 2 | Valve Body Top | Ductile Iron ASTM A536 65-45-12 |
| 3 | Valve Body Gasket | EPDM Rubber |
| 4 | Resilient Wedge Gate | Ductile Iron ASTM A536 65-45-12 * |
| 5 | Stem Nut | Bronze ASTM B584 |
| 6 | Valve Stem | Bronze ASTM B584 |
| 7 | Bonnet Gasket | EPDM Rubber |
| 8 | Bonnet Retainer Ring | Ductile Iron ASTM A536 65-45-12 |
| 9 | Bonnet | Ductile Iron ASTM A536 65-45-12 |
| 10 | Stem Gland | Ductile Iron ASTM A536 65-45-12 |
| 11 | 2" Operator Nut | Ductile Iron ASTM A536 65-45-12 |
| 12 | Stem O-rings | EPDM Rubber |
| 13 | Bonnet O-ring | EPDM Rubber |
| 14 | Bonnet Bolts/Nuts/Washers | Zinc Plated Steel or 304SS (optional) |
| 15 | Valve Body Bolts/Nuts/Washers | Zinc Plated Steel or 304SS (optional) |
| 16 | Stem Gland Bolts | Zinc Plated Steel or 304SS (optional) |
| | | *EPDM Encapsulated ASTM D429 |

| Nominal Size | 4" | 6" | 8" | 10" | 12" |
|------------------|-----------------------------|-----------------------------|-----------------------------|-------------------------------|--------------------------------|
| A (mm) | 21 1/2" (546) | 24 1/4" (616) | 29" (737) | 38 1/2" (978) | 41 1/2" (1054) |
| B (mm) | 16" (406) | 18" (457) | 20" (508) | 25" (635) | 30" (762) |
| C (mm) | 9 1/2" (241) | 11 1/4" (286) | 13 1/2" (343) | 15 3/4" (400) | 18" (457) |
| F (mm) | 4.5" - 5.26" (114 - 134) | 6.63" - 7.2" (168 - 183) | 8.63" - 9.3" (219 - 236) | 10.75" - 11.3" (273 - 287) | 12.75" - 13.42" (324 - 341) |
| G (mm) | 13 1/4" (337) | 15 1/4" (387) | 17 1/2" (445) | 21" (533) | 24" (610) |
| H (mm) | 13 1/2" (343) | 16" (406) | 19" (483) | 23 1/2" (597) | 27 1/2" (699) |
| Weight (approx.) | 260 LBS 118 kg | 320 LBS 145 kg | 450 LBS 204kg | 1000 LBS 454 kg | 1300 LBS 590 kg |

*Data subject to change without notice / Dimensions not for construction unless certified

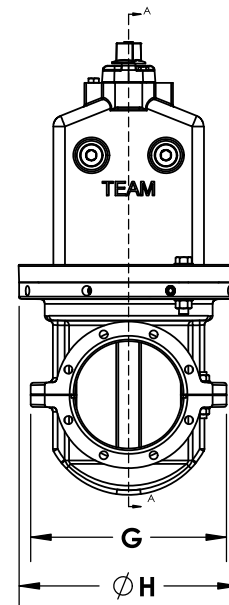

TEAM®